



FIRESTOP CENTRE

Authorised New Zealand Distributor
Ph (09) 483 4000 www.firestopcentre.co.nz

AGNI-Wrap in 2 x 13mm Plasterboard Wall or
116mm Concrete Wall
20mm PEX-AL-PEX Pipe
Max FRR -/120/120

Step-by-step installation instructions:

1. Ensure the aperture is free from dust and debris.
2. Cut the necessary length of AGNI-Wrap 50.
3. Insert one layer of AGNI-Wrap 50 into the aperture each side of the wall, leaving 10mm extending out of the wall.
4. Apply a bead of AGNI-Seal (5mm nominal) between the wall and AGNI-Wrap.
5. Fill any gap between AGNI-Wrap 50 and the pipe with AGNI-Seal, finished flush with the edge of AGNI-Wrap 50.

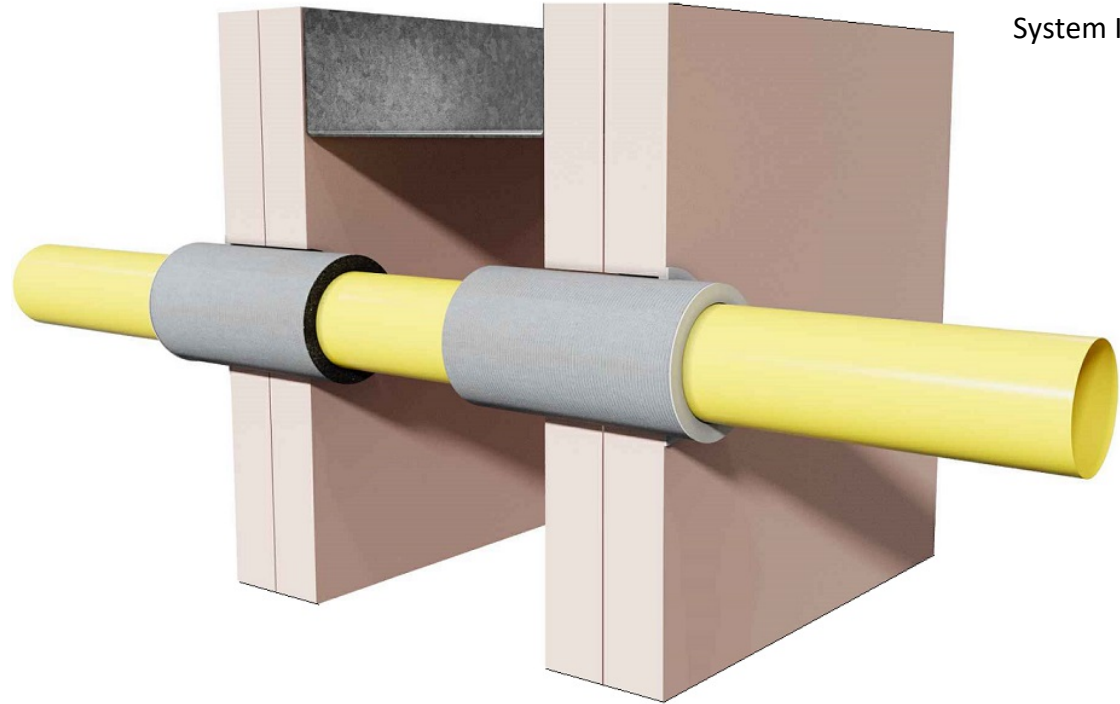

System ID# FC852

Technical Information

Substrate	<ul style="list-style-type: none"> • Min. 64mm steel / timber stud wall with a minimum of two layers of 13mm (or greater) FR plasterboard on each side, with or without insulation. • Min. 116mm concrete wall/masonry wall/block wall
Service range	DN 20mm PEX-AL-PEX pipe
Annular gap	6-13mm
AGNI-Products	AGNI-Wrap 50, AGNI-Seal
Protection installation	Both sides of the wall

Compliance Information

Standards	AS1530.4-2014, AS4072.1-2005
FRR/FRL	-/120/120
Reference	RIRF24100 AP-100



8 Clare St Bayswater
VIC 3153, AUSTRALIA
www.agnitek.com.au

Disclaimer

Agnitek reserves the right to modify product specifications without prior notice due to its ongoing research, development & certification programme. The information in this document is provided in good faith and is intended for guidance purposes only. Any accompanying drawings are solely for illustrative purposes. Since Agnitek cannot oversee installation methods or ensure site conditions, no warranties, expressed or implied, are intended regarding the products' actual performance. We do not accept liability for any loss, damage, or injury from using this information. Please take a look at the test reports displayed on a relevant AGNI-System webpage for all compliance specifics.

Date | 20.06.2024



FIRESTOP CENTRE

Authorised New Zealand Distributor
Ph (09) 483 4000 www.firestopcentre.co.nz

AGNI-Wrap in 2 x 13mm Plasterboard Wall or 116mm Concrete Wall 20mm PEX-AL-PEX Pipe Max FRR -/120/120

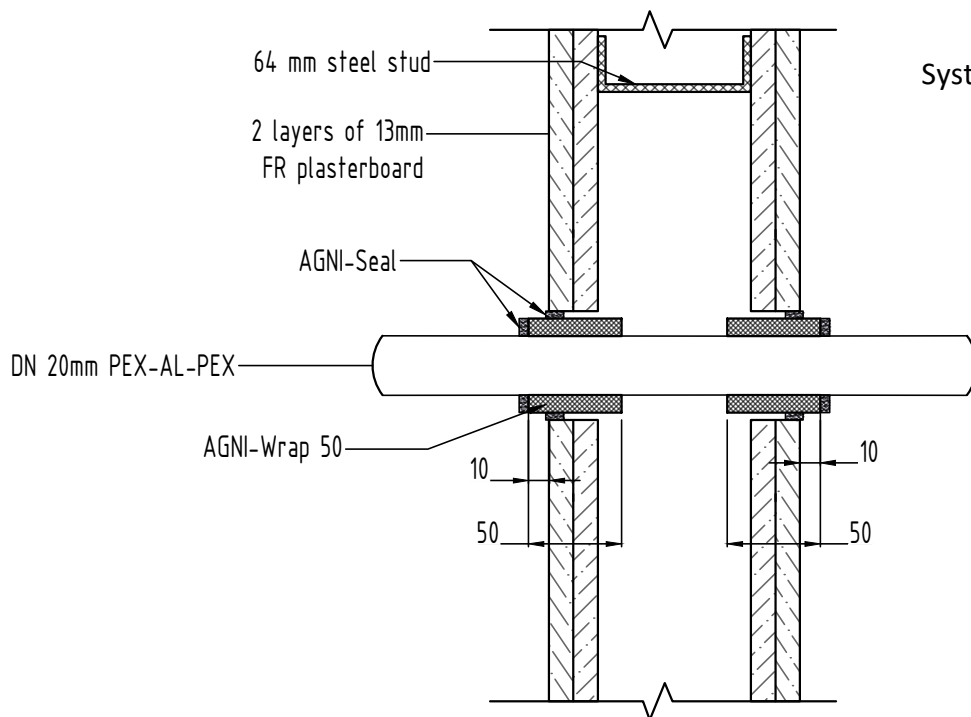

System ID# FC852

Technical Information

Substrate	<ul style="list-style-type: none"> Min. 64mm steel / timber stud wall with a minimum of two layers of 13mm (or greater) FR plasterboard on each side, with or without insulation. Min. 116mm concrete wall/masonry wall/block wall
Service range	DN 20mm PEX-AL-PEX pipe
Annular gap	6-13mm
AGNI-Products	AGNI-Wrap 50, AGNI-Seal
Protection installation	Both sides of the wall

Compliance Information

Standards	AS1530.4-2014, AS4072.1-2005
FRR/FRL	-/120/120
Reference	RIRF24100



8 Clare St Bayswater
VIC 3153, AUSTRALIA
www.agnitek.com.au

Disclaimer

Agnitek reserves the right to modify product specifications without prior notice due to its ongoing research, development & certification programme. The information in this document is provided in good faith and is intended for guidance purposes only. Any accompanying drawings are solely for illustrative purposes. Since Agnitek cannot oversee installation methods or ensure site conditions, no warranties, expressed or implied, are intended regarding the products' actual performance. We do not accept liability for any loss, damage, or injury from using this information. Please take a look at the test reports displayed on a relevant AGNI-System webpage for all compliance specifics.

Date	20.06.2024
------	------------